

# StowAway2

## Cargo Carriers

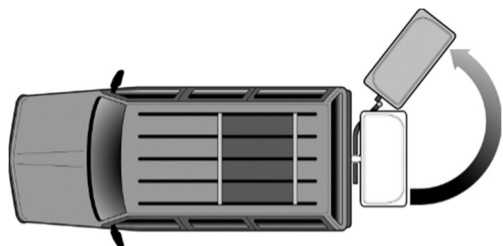

### Assembly Instructions

StowAway SwingAway Frame  
Part # ST 022.9, 022.91, 022.92  
(Rev. 0218)

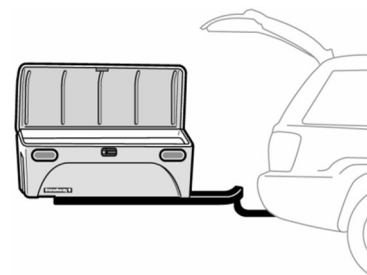

Please review the instructions and safety guidelines carefully before assembling the StowAway Swingaway Frame. Assembly and installation of the frame are solely the end user's responsibility.

See [www.StowAway2.com](http://www.StowAway2.com) for more information and videos about assembling the Swingaway Frame.

### StowAway Warnings and Guidelines

- **EXHAUST WARNING** – Hot exhaust directed at or below the Swingaway frame could melt or damage items that you have mounted to the frame. For vehicles with straight back exhaust it is recommended that the exhaust be diverted with an exhaust pipe tip or deflected away from your contents with an exhaust shield. Exhaust shields are not necessary on vehicles with tail pipes that direct the exhaust downward or to the side of your contents.
- The Swingaway Frame is not intended for off-road use.
- Swingaway models designed for a 2" hitch receiver should be used with a Class III or IV 2" receiver hitch. Swingaway models designed for a 1.25" hitch receiver should be used with a Class II, 1.25" hitch receiver. We do not recommend the use of a 1.25" to 2" hitch converter with the Swingaway frame under any conditions. A seven inch hitch extender can be used with Class III or IV hitches rated for more than 500 pounds tongue weight. Under no circumstances should the hitch tongue weight, vehicle tongue weight, or the vehicle gross vehicle weight be exceeded.
- Before driving, be sure that the SwingAway frame is latched and both safeties are engaged. The frame should be regularly inspected for signs of wear, corrosion and/or fatigue.
- Rinse and lightly oil the Swingaway frame and hardware after traveling on salted roads or when using the frame in a salt air environment. Coating the inside and outside of the frame with a rust preventive product is advised in the case of regular exposure to salt or salt air.



# StowAway<sup>2</sup>

## Cargo Carriers

### SwingAway Frame

1. Swing Arm
2. Bent Hitch bar

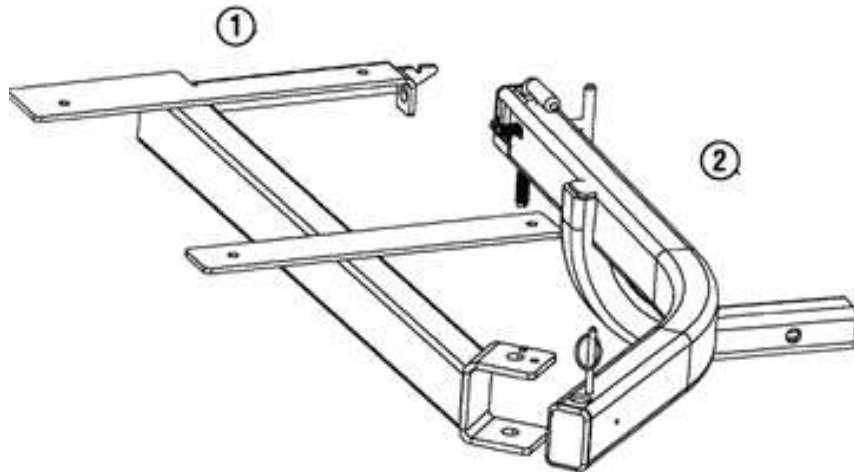

### Hardware Kit

- 1 - 3/4" Pivot Bolt
- 4 - Flat Washers for Pivot Bolt
- 1 - 3/4" Nylok Lock Nut for Pivot Bolt
- 1 - Hitch Pin (Not included if hitch lock is ordered)
- 1 - Hitch Tightener

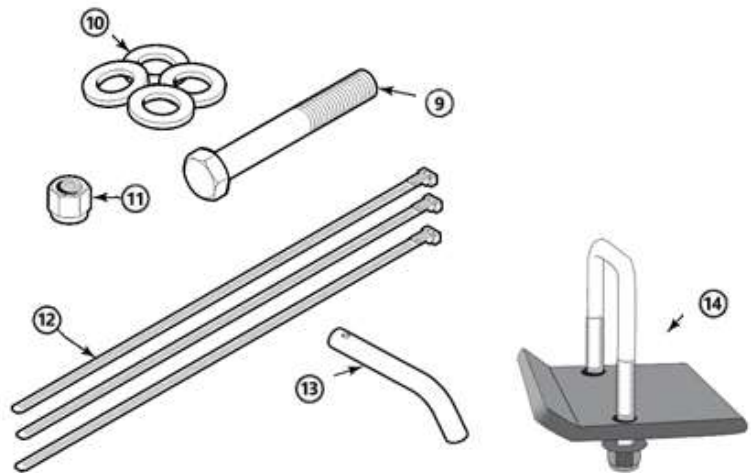

### Tools Required for Assembly

Two large adjustable end wrenches or socket wrenches with 9/16" and 1 1/8" sockets.

# StowAway2

## Cargo Carriers

### 1. Assembling the Frame

- Slide the Bent Hitch Bar into your vehicle's trailer hitch until the hitch pin holes are aligned (Fig 1). Locate the Hitch Pin or Hitch Lock from the hardware kit and insert the pin into the hitch. The hitch tightener need not be installed at this time unless you plan to use the Swingaway frame immediately.
- Fit the swing arm yoke over the point of rotation on the hitch bar (Fig 2). Position two pivot bolt washers (Fig 3), one on top of the yoke and one between the yoke and bar, then insert the pivot bolt through the yoke and the hitch bar. Insert the third washer the yoke and bar (grease washer and tap into place if it is tight) before pushing the pivot bolt through the bottom of the yoke. Add the fourth washer to the end of the pivot bolt after the bolt is all the way through. Hand tighten the nylok lock nut onto the pivot bolt until you feel resistance, then with two large wrenches, tighten the nut all the way to the bottom of the yoke. Note, it is normal for the nylok to require firm pressure when being tightened.
- Test the frame to ensure that the Swing Arm swings freely.
- Close the swing arm until the plunger pin engages and holds the frame closed. The frame has been welded so that the spear comes in at or just above the latch hole when swung closed. If your spear comes in high, add your gear box or rack to the frame, load it, and swing it closed again. If necessary, push down firmly on the end of your gear box or rack when closing the frame. Once loaded and latched your frame will slowly conform to the closed position. For questions, watch the assembly video on our website.

Fig 1

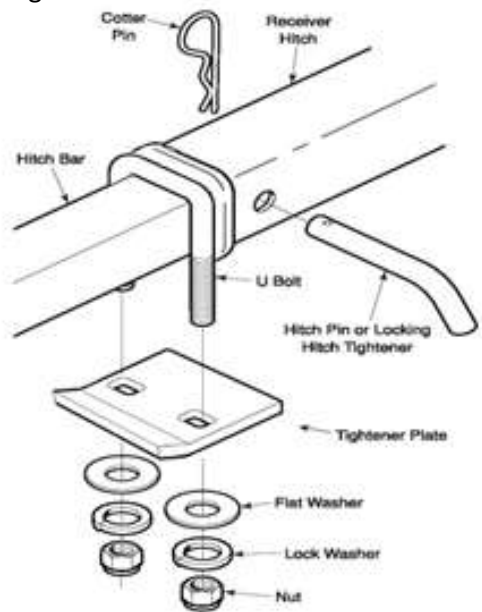

Fig 2

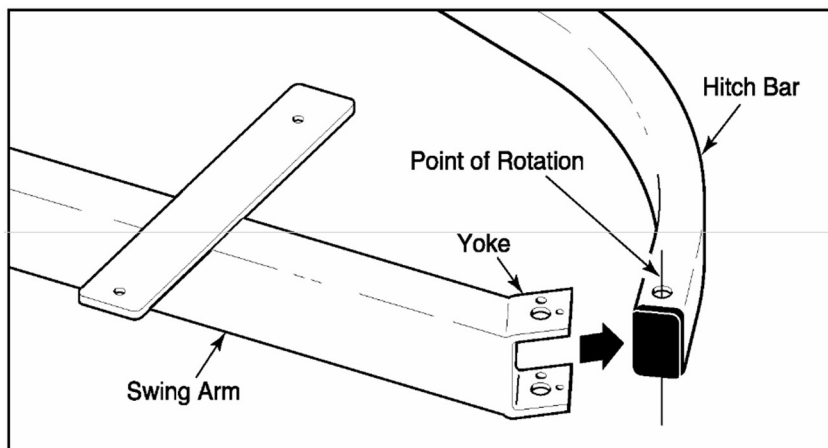
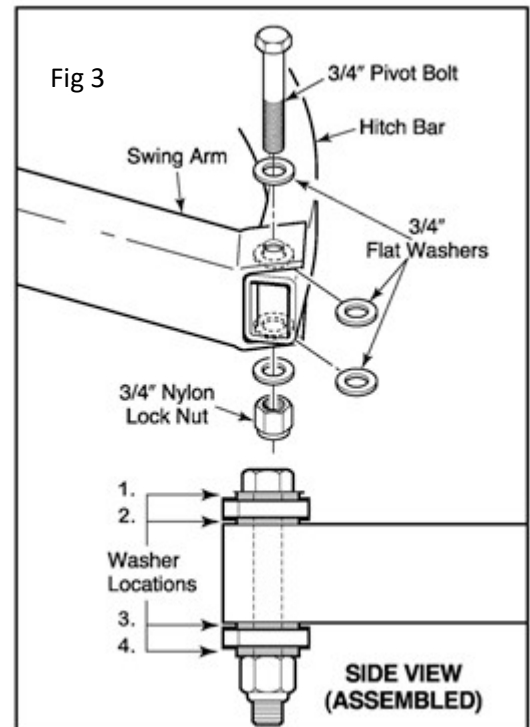

Fig 3



# StowAway<sup>2</sup>

## Cargo Carriers

### Using the Swingaway Frame

1. The SwingAway frame is equipped with a latch, a threaded safety and a secondary safety. To close the frame, swing it closed until the latch engages. Tighten the primary T-Bolt safety fully until the T-Bolt washer is flush to the frame. Be sure that the threads are properly aligned when tightening the bolt. Drop the secondary safety into place at the pivot point.
2. To open the frame remove both safeties, pull up on the orange plunger pin and swing the frame open.
3. The SwingAway frame may be locked at 90 degrees from the vehicle by inserting the secondary safety pin into hole at the pivot point. Care should be taken when swinging the frame open near traffic or on an incline. Your gear should be loaded with the frame in the closed position if possible.
4. The frame includes four holes for mounting a gear box or rack to the frame with 3/8" bolts, washers and nuts.



# **StowAway2**

## **Cargo Carriers**

### **Warranty on the Swingaway Frame**

Pacific Recreational Products, Inc. (PRP) warrants to the original retail purchaser of the StowAway Cargo Carrier that the carrier is and shall remain free of defects, including materials and workmanship, for a period of ten years from the date of retail purchase.

Should the purchaser discover a defect and notify PRP during this 10-year warranty period, PRP will, at its sole discretion, either (A) repair or replace the unit at no additional charge, or (B) refund all or part of the customer's original purchase price.

This 10-year limited warranty does not cover normal wear & tear, damage caused by exhaust gasses, rust or corrosion, or damage caused by collision, disaster, abuse, modification, or misuse. Misuse includes, but is not limited to overloading of the carrier, improper installation, use with any hitch receiver of an incorrect size or style, or moderate to heavy off-road use.

Limited warranty service may be obtained by first calling or writing to PRP and describing the problem or perceived defect. PRP may request documentation in order to fully understand the nature of the problem or defect. If a defect or problem is confirmed, PRP will, at its sole discretion, replace, repair, or authorize the return of the product in the original shipping container or its equivalent. Unless otherwise authorized, return transportation charges must be prepaid by the purchaser.

All express and implied warranties for this product, including the warranties of merchantability and fitness for a particular purpose, are limited in duration to a period of ten years from the date of purchase. No warranties, whether expressed or implied, will apply after this period.

If this product is defective, your sole remedy shall be repair, replacement, or refund as provided above. In no event will PRP or any of its officers, employees, or agents be liable to you for any damages. This includes incidental or consequential damages arising out of the use of or inability to use the cargo carrier, even if PRP has been advised of the possibility of such damages, or for any claim by another party.

To initiate a warranty claim, please fill out the Return Request Form on our Returns & Exchanges page. Consult our website [StowAway2.com](http://StowAway2.com) for assembly videos and other product information.

Pacific Recreational Products, Inc.  
7291 SW Tech Center Drive • Tigard, OR 97223  
Ph.: 800.943.5377 • Fax: 503.968.1433

[StowAway2.com](http://StowAway2.com)

E-mail: [customerservice@StowAway2.com](mailto:customerservice@StowAway2.com)

Thank you for purchasing a StowAway Carrier product!

